

SAGIO™

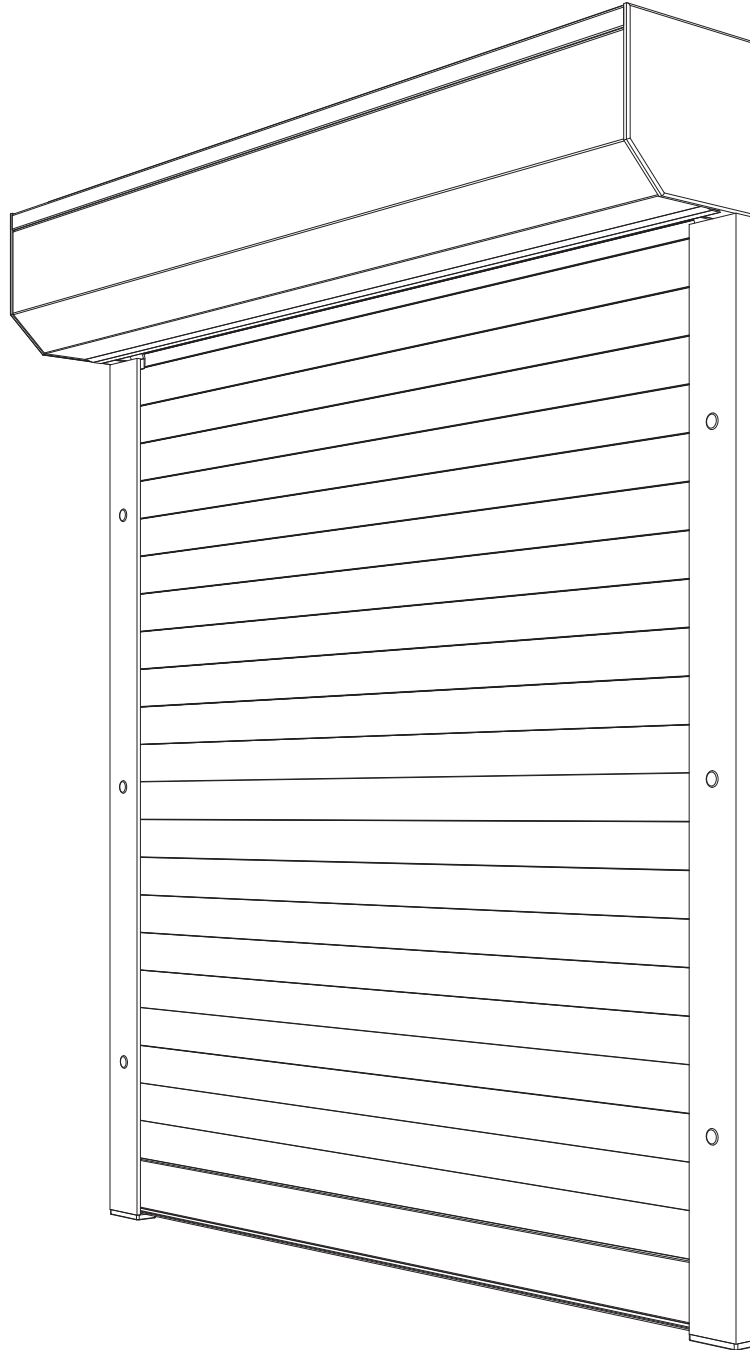

DEUTSCH

Je nach Bauart bzw. individuellem Schema des Produktes kann die Anzahl und Art von Zubehörteilen im Set variieren.

ENGLISH

Depending on the design and the individual wiring diagram of the product, the number and type of accessories can vary with each kit.

FRANÇAIS

En fonction de la structure et du schéma du produit, le nombre et le type d'accessoires dans chaque kit peut varier.

POLSKI

W zależności od konstrukcji oraz indywidualnego schematu produktu liczba oraz rodzaj elementów akcesoriów w każdym zestawie może się różnić.

ITALIANO

Il numero e il genere di elementi accessori in ogni completo può variare in relazione alla struttura e allo schema del prodotto specifico.

ESPAÑOL

En función de la construcción y el esquema específico del producto, puede variar la cantidad y el tipo de accesorios de cada conjunto.

NEDERLANDS

Afhankelijk van het ontwerp en het afzonderlijke schema kan het aantal en het type accessoire(s) in elk pakket variëren.

TÜRK

Ürünün yapısı ve bireysel şemasına bağlı olarak takımlardaki aksesuar sayısı ve türü farklı olabilir.

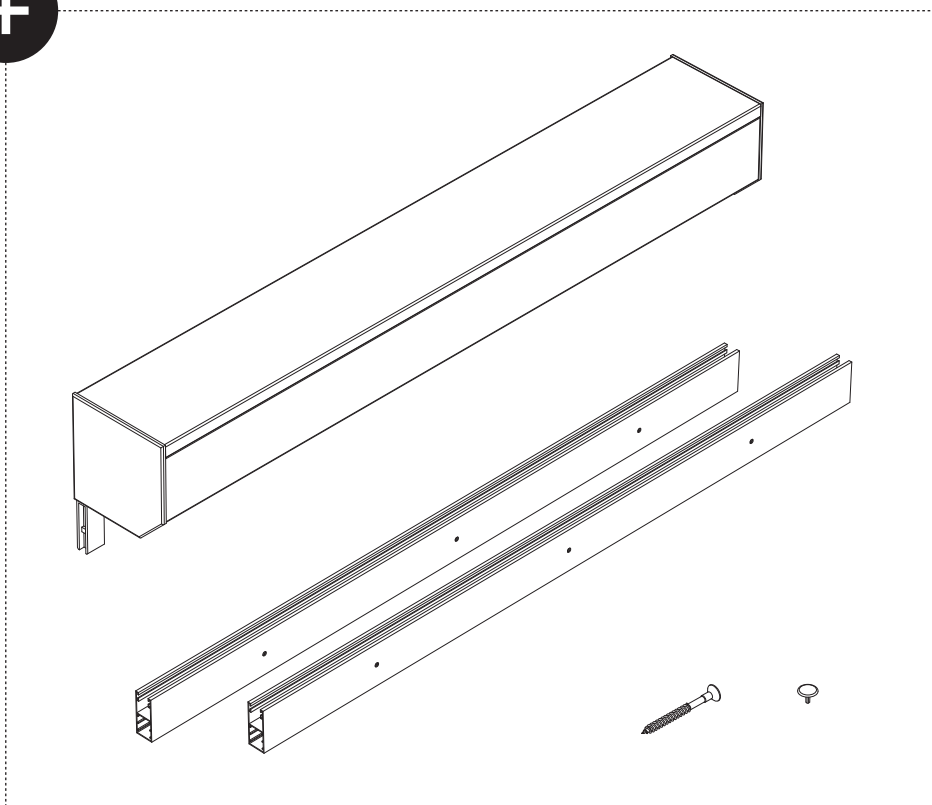

ZUBEHÖR
ACCESSORIES
ACCESSOIRES
AKCESORIA
ACCESSORI
ACCESORIOS
ACCESSOIRES
AKSESUARLAR

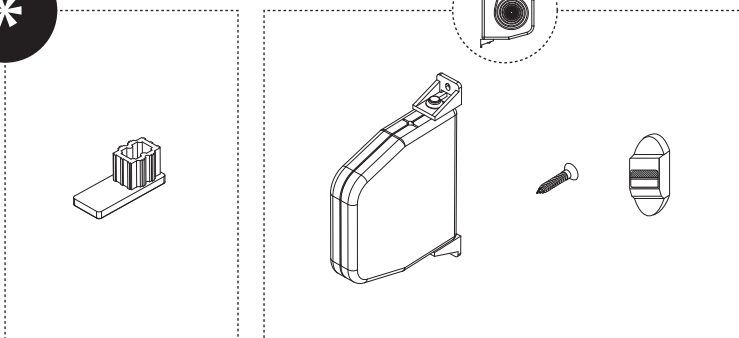

FAKULTATIV
OPTIONAL
OPTIONNEL
OPCJONALNIE
OPZIONALE
OPCIONAL
FACULTATIEF
OPSIYONEL

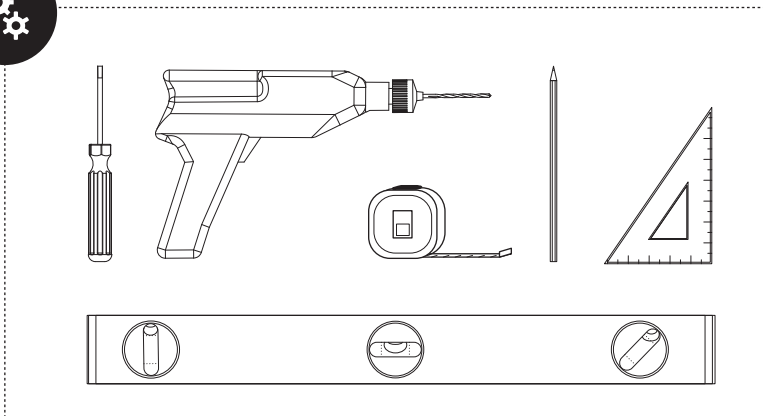

BENÖTIGTE WERKZEUGE
TOOLS REQUIRED
OUTILS REQUIS
POTRZEBNE NARZĘDZIA
STRUMENTI NECESSARI
HERRAMIENTAS NECESARIAS
BENODIGD GEREEDSCHAP
ARAÇLAR GEREKLİ

V1

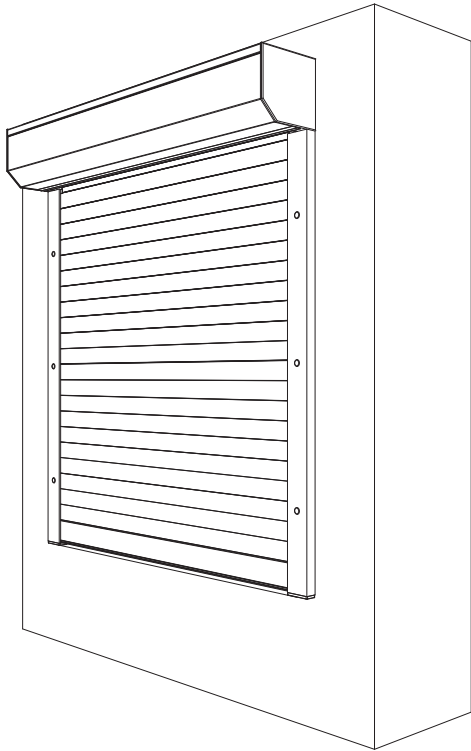

V2

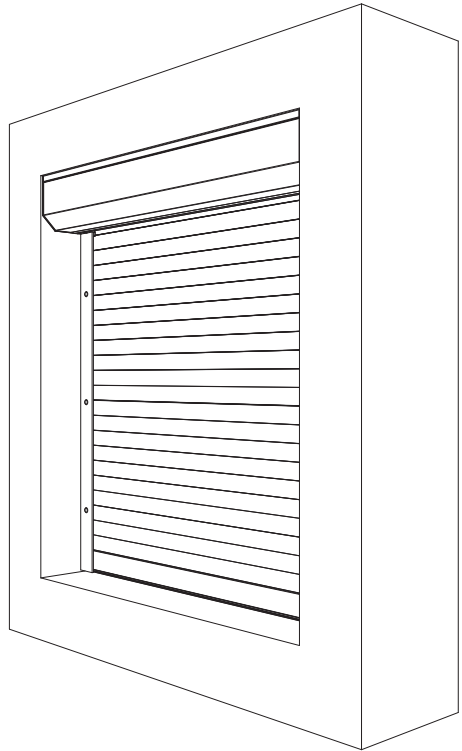

V3

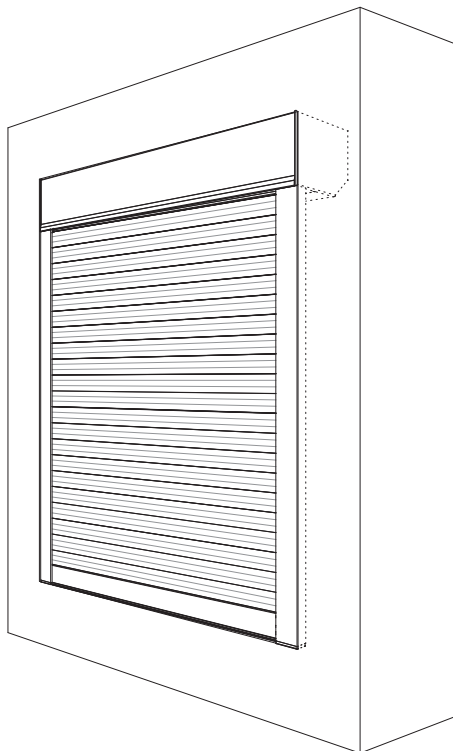

1

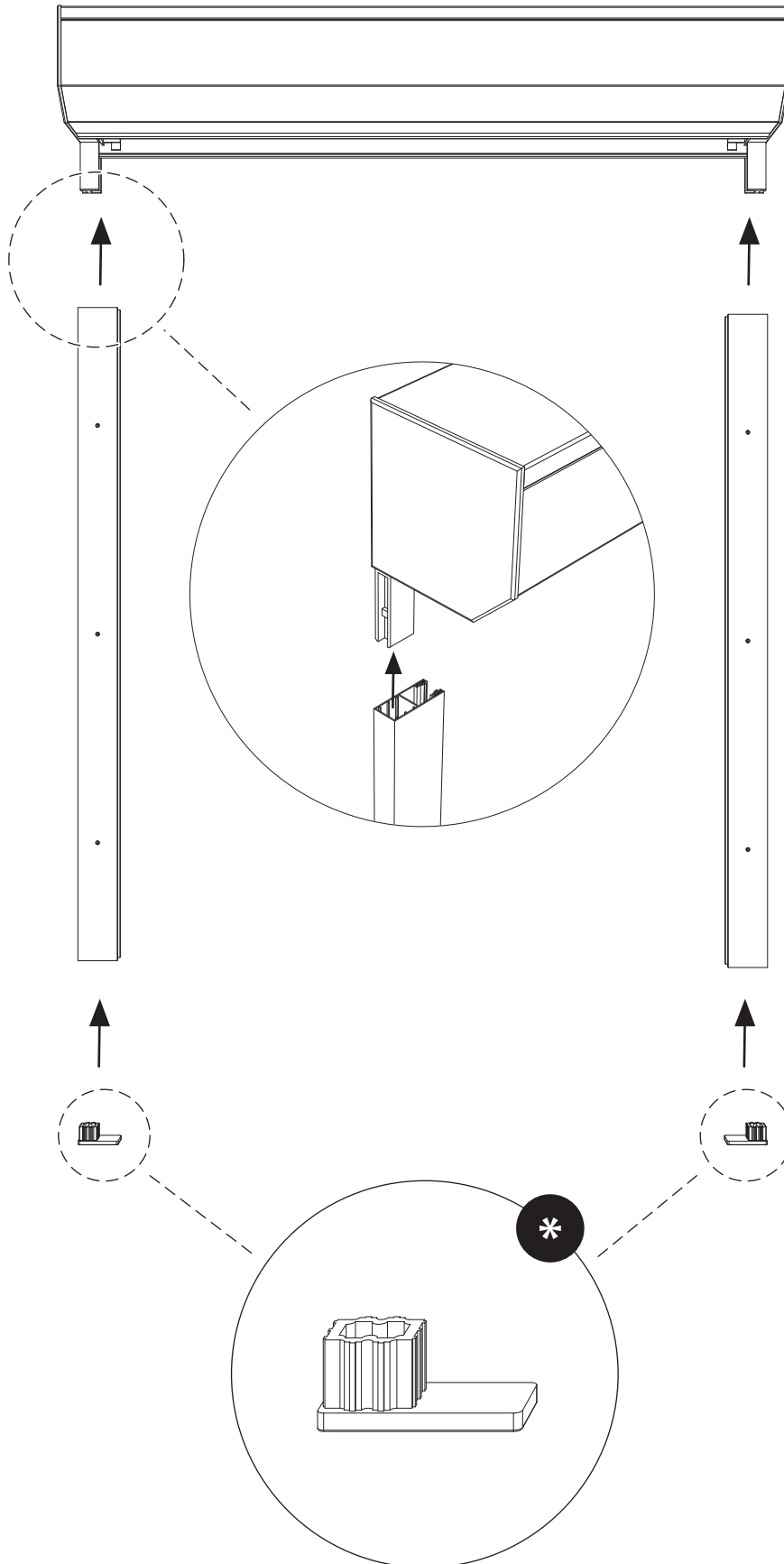

2 V1

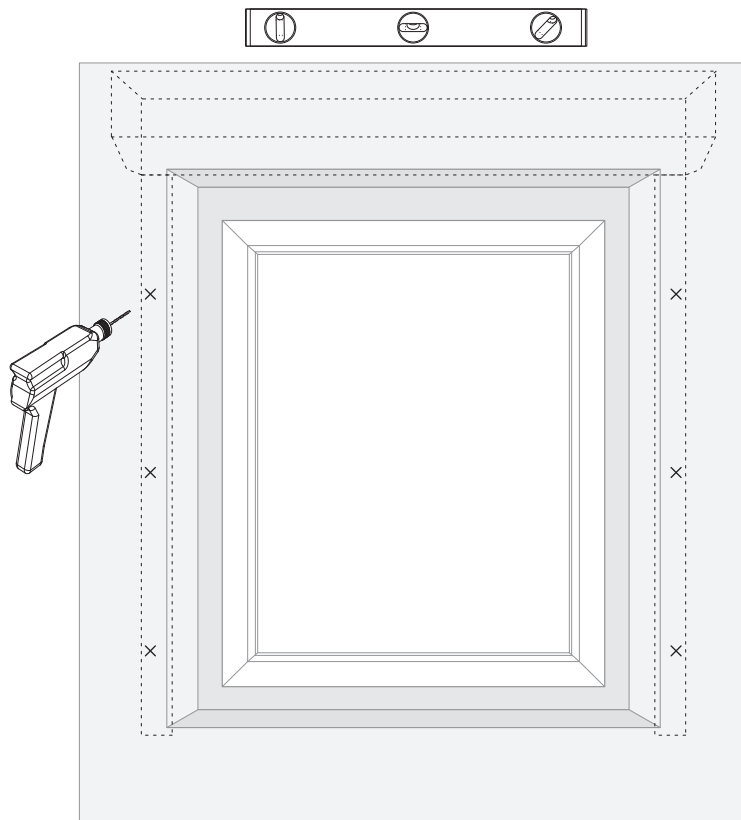
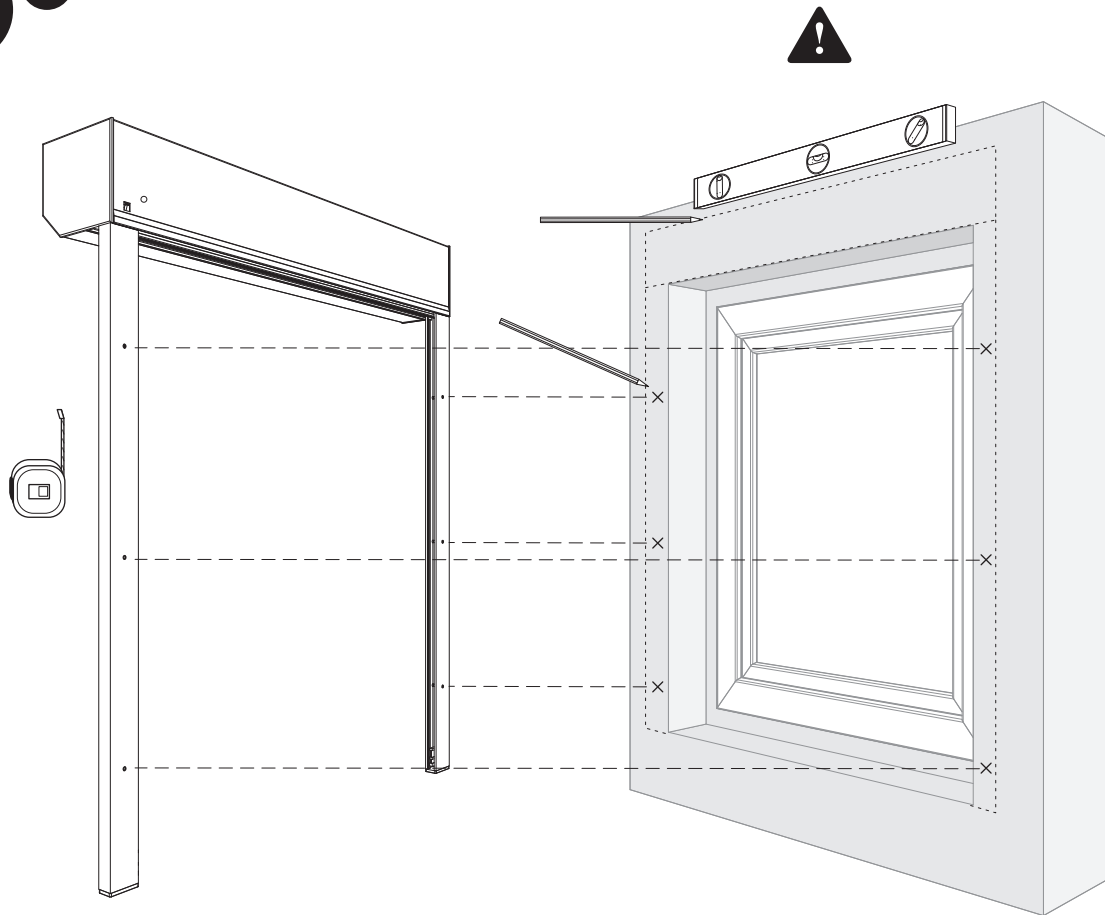

3 V1

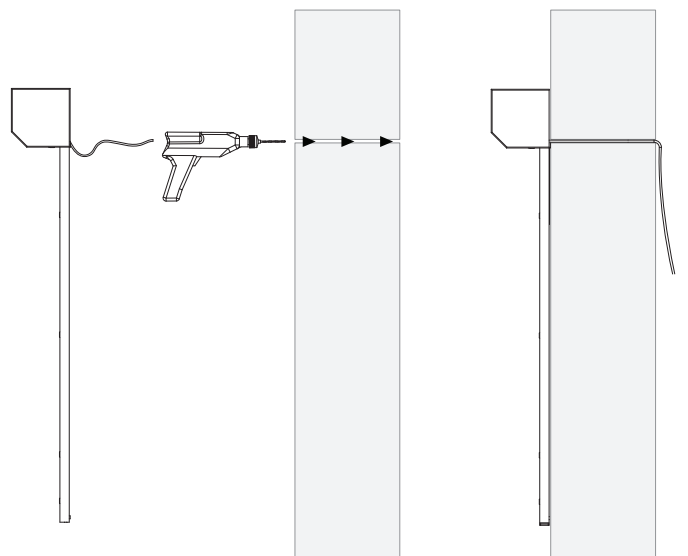
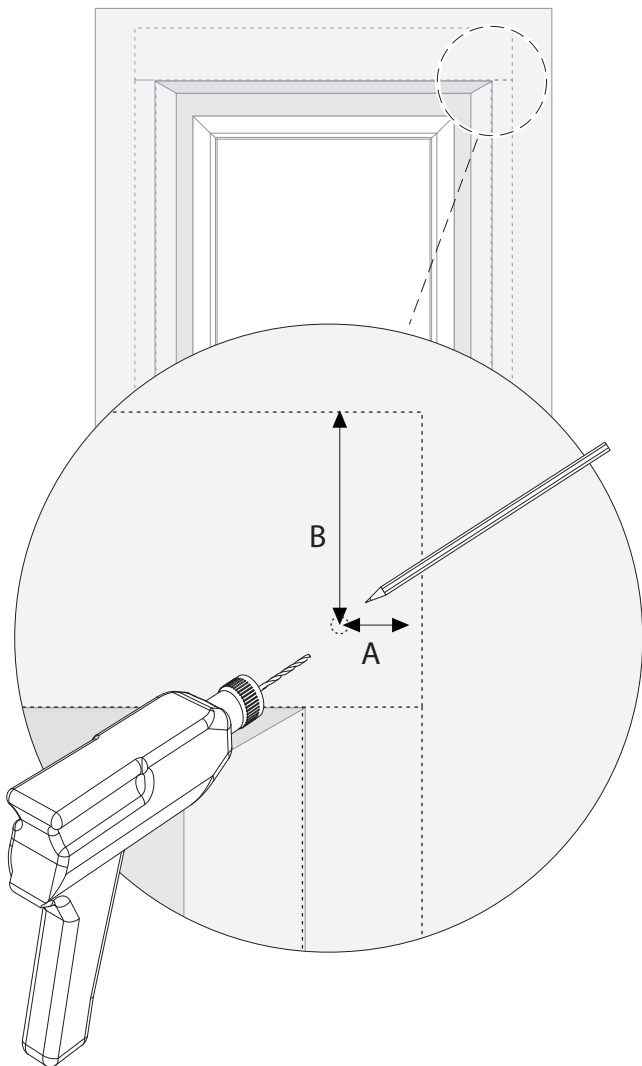
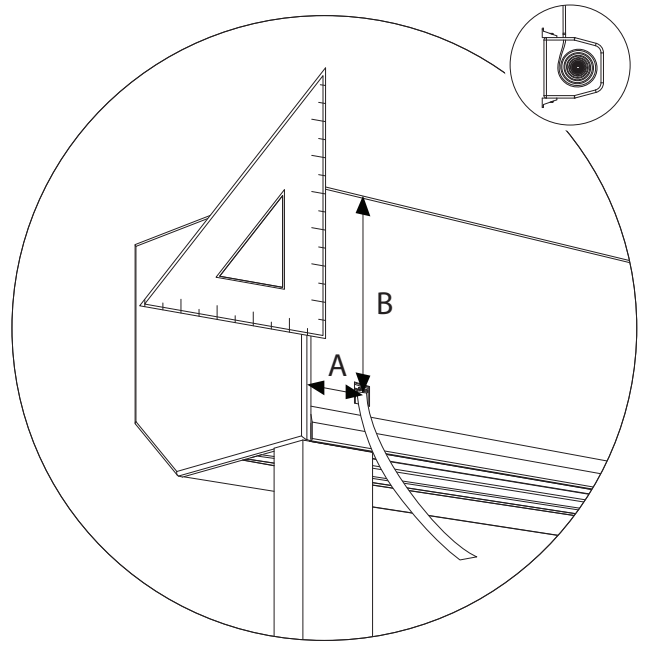
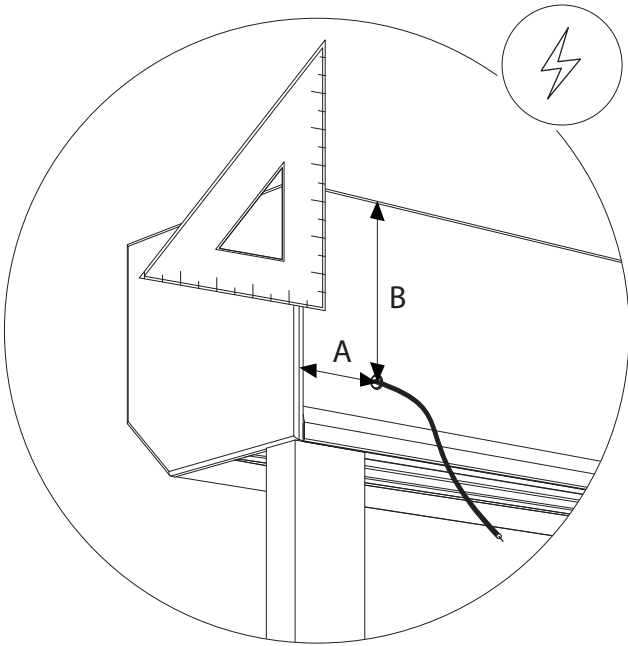

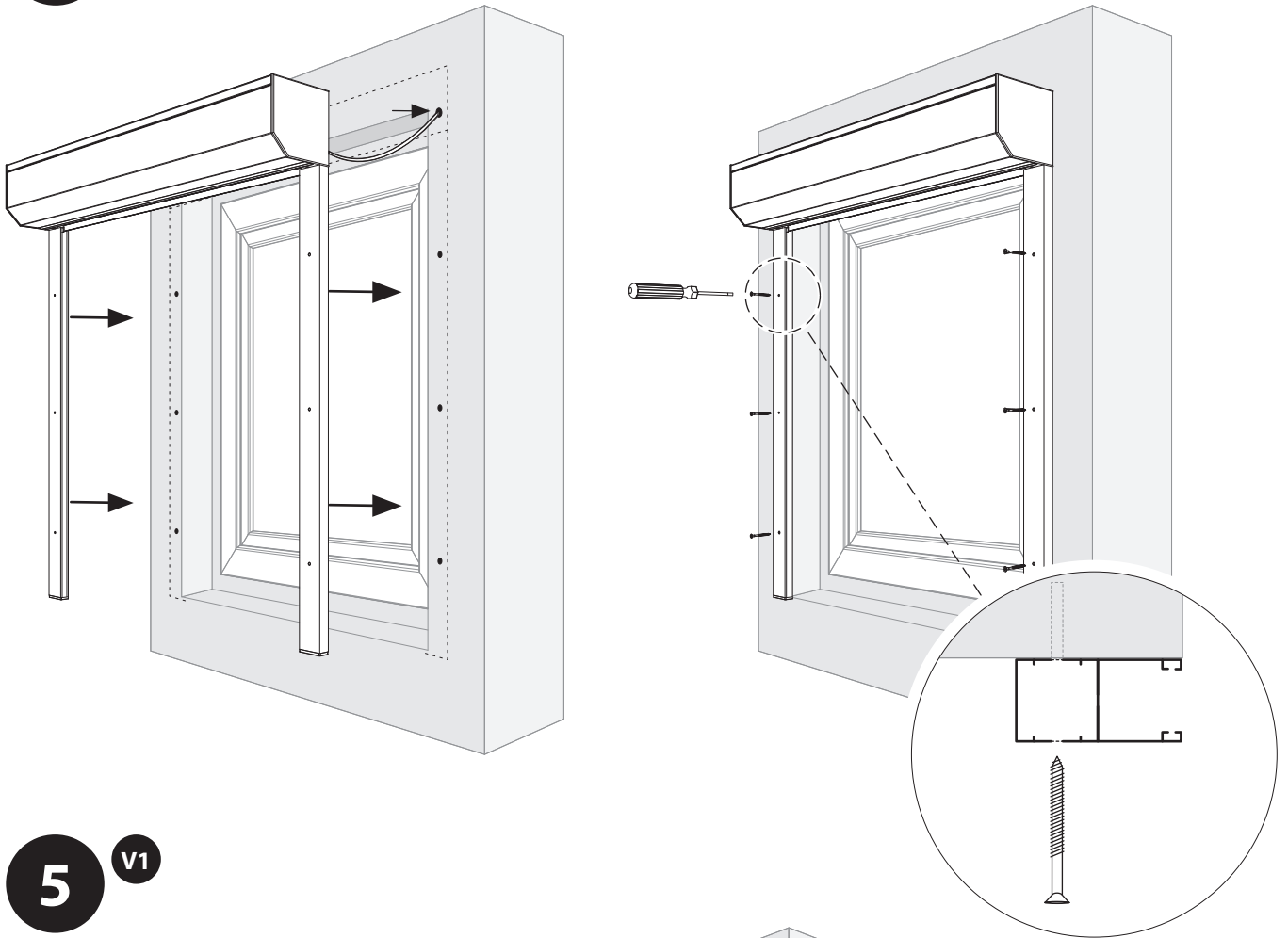
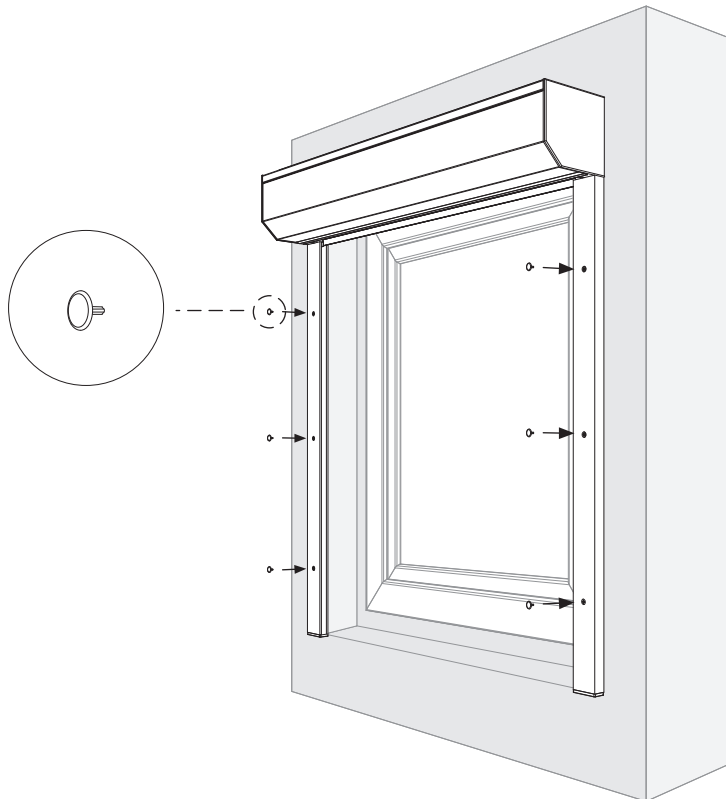
4 V1**5** V1

2 V2

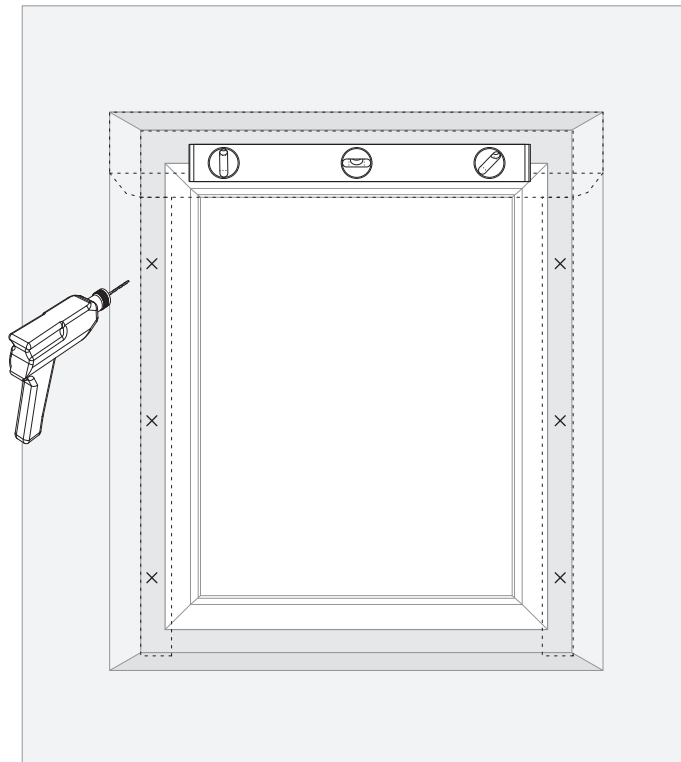
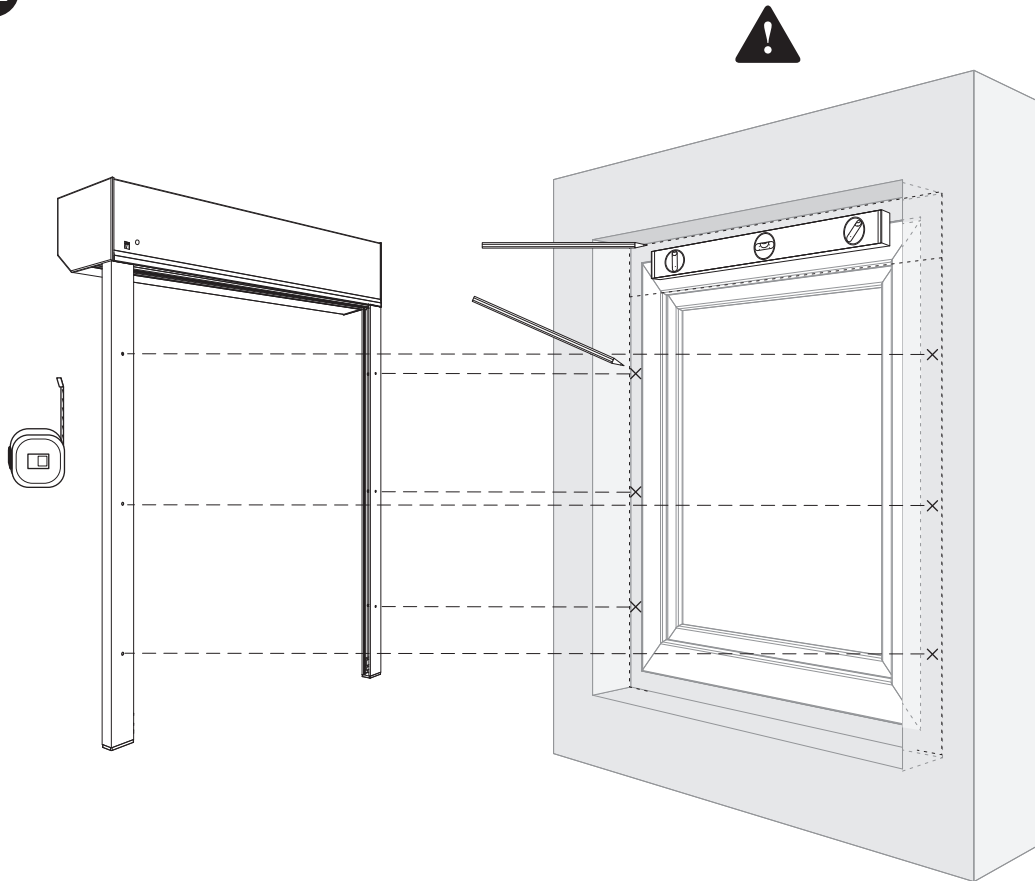

3

V2

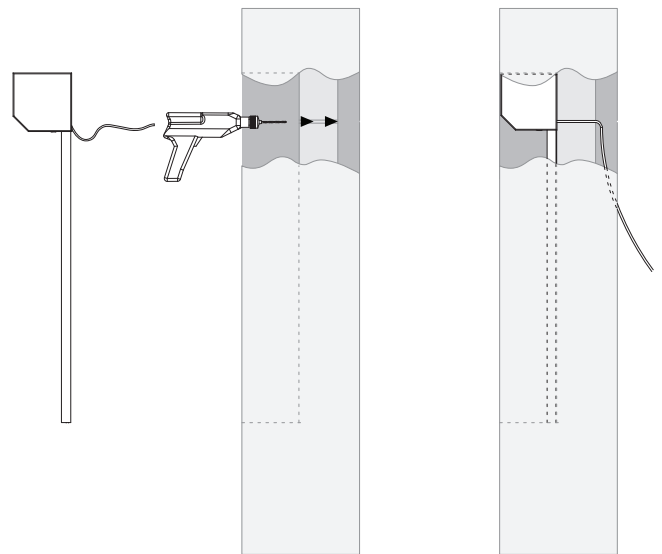
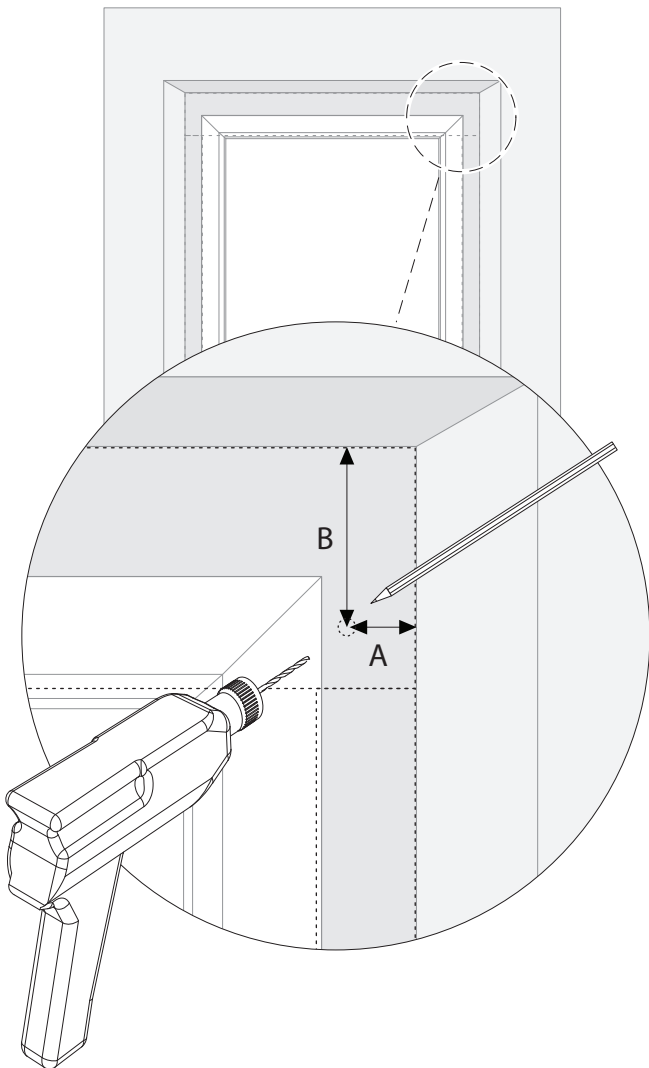
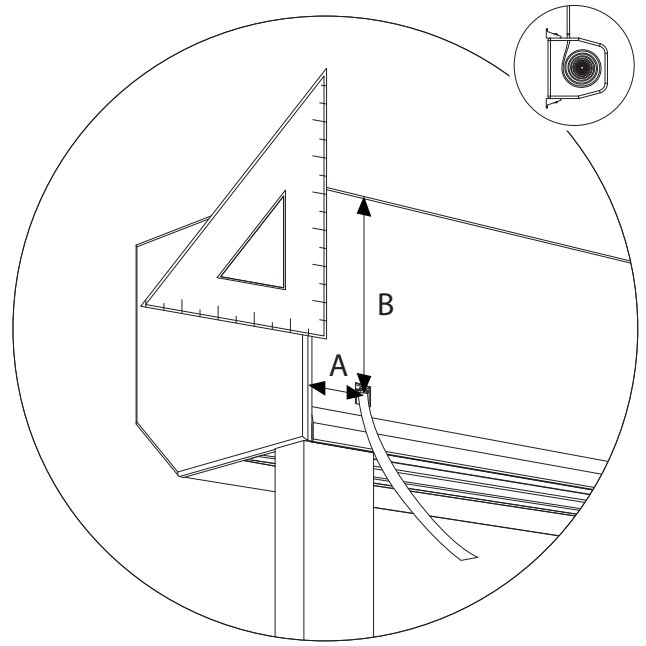
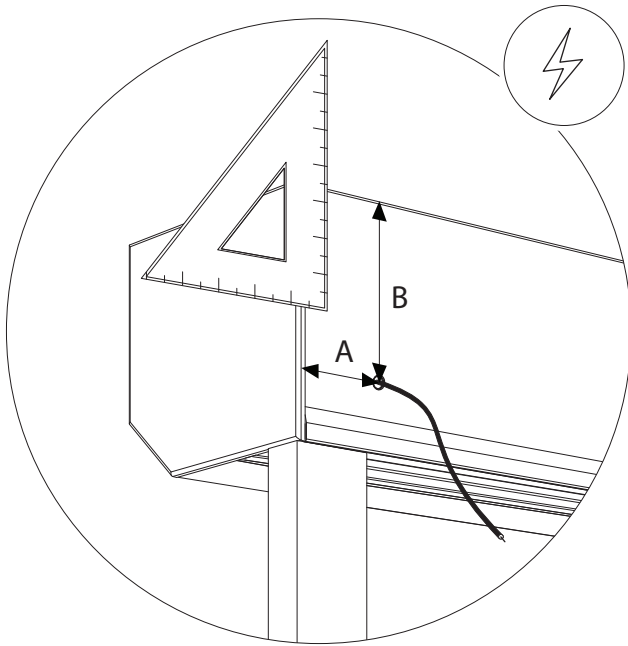

4 ^{V2}

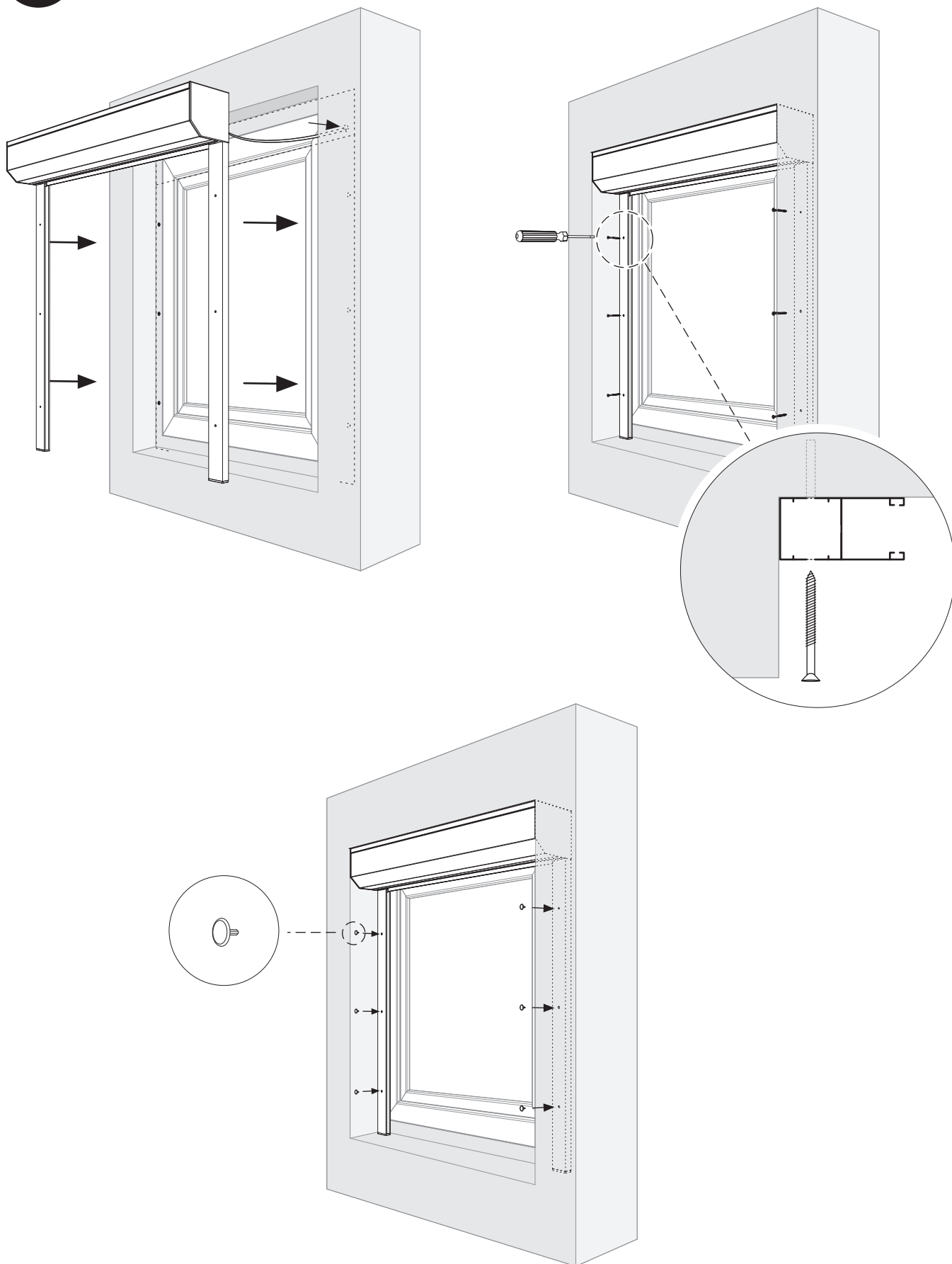

2 V3

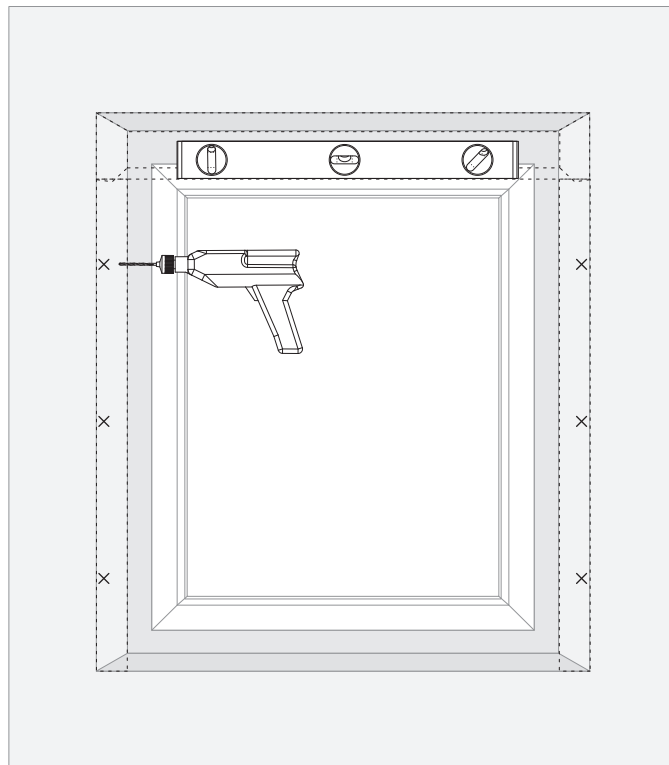
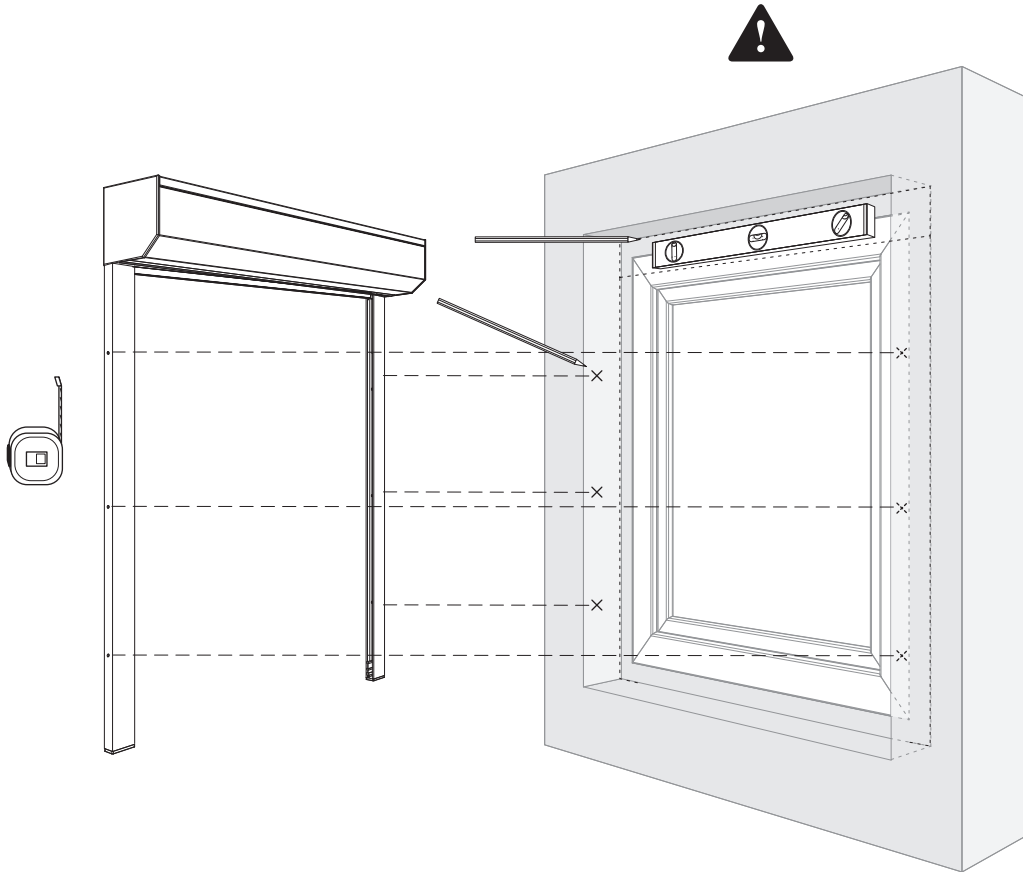

3

V3

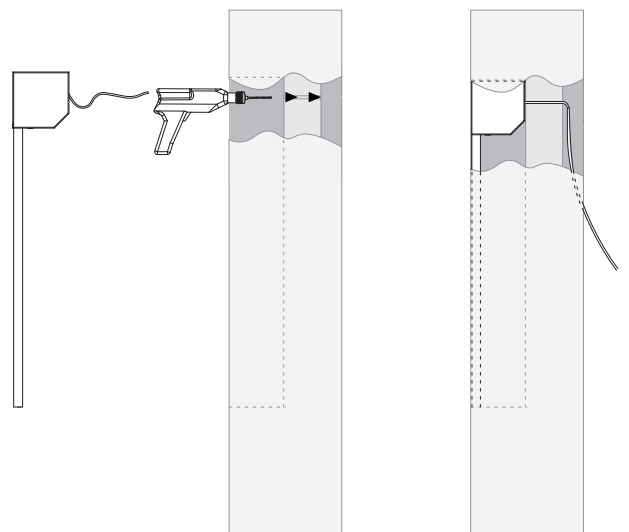
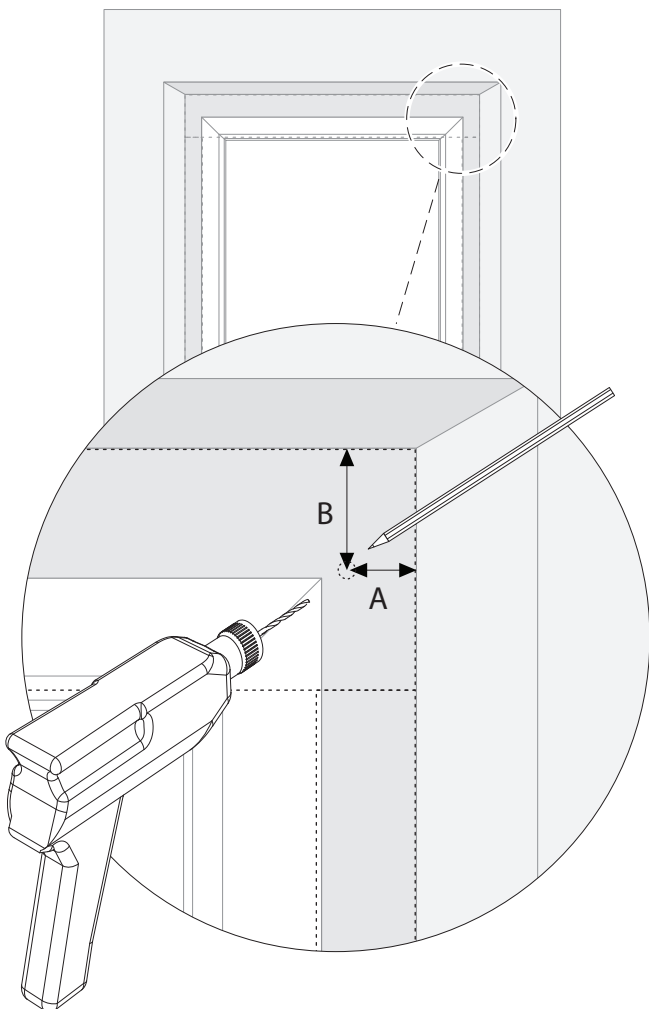
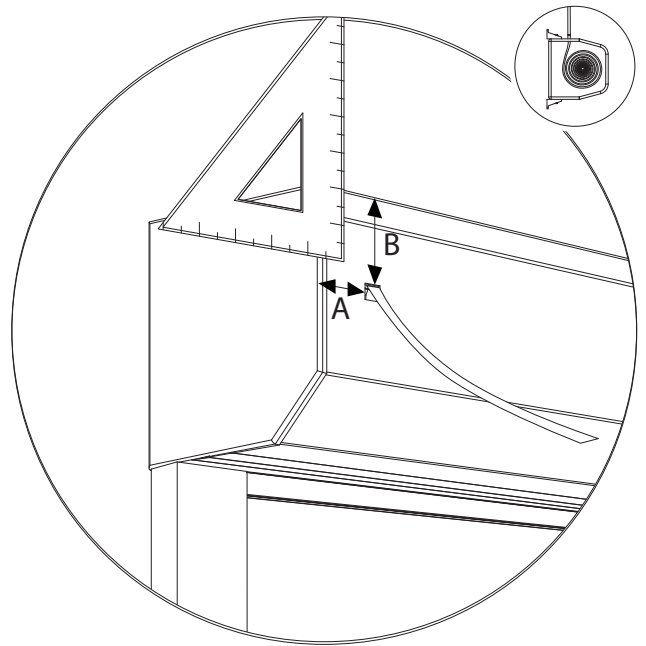
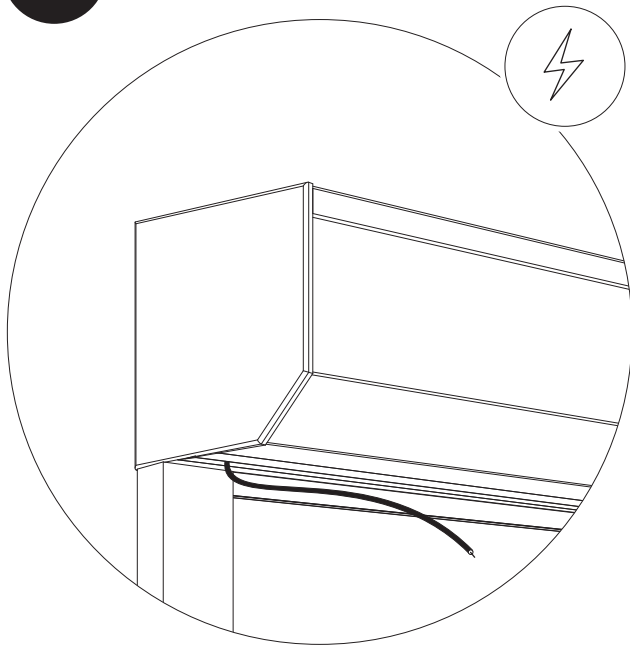

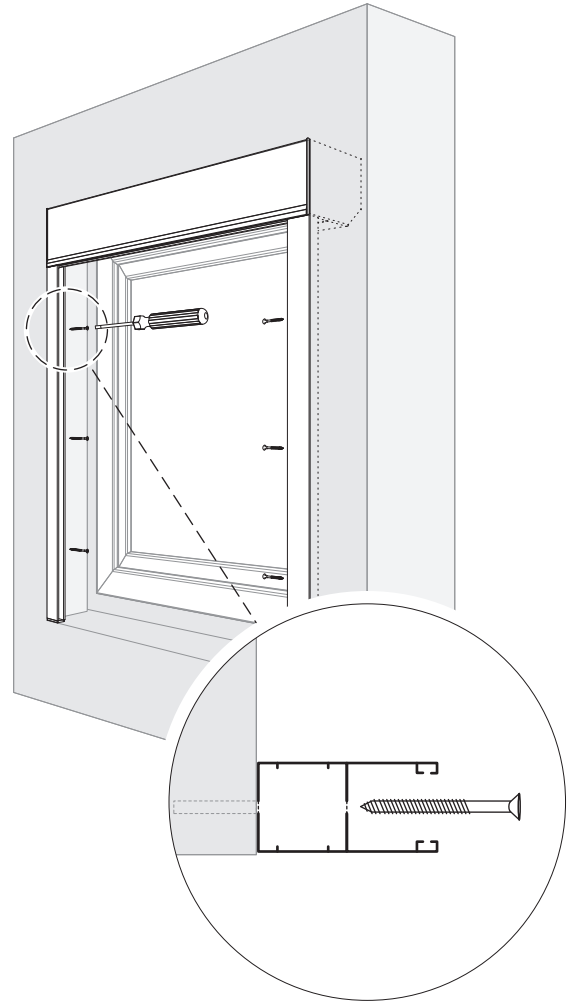
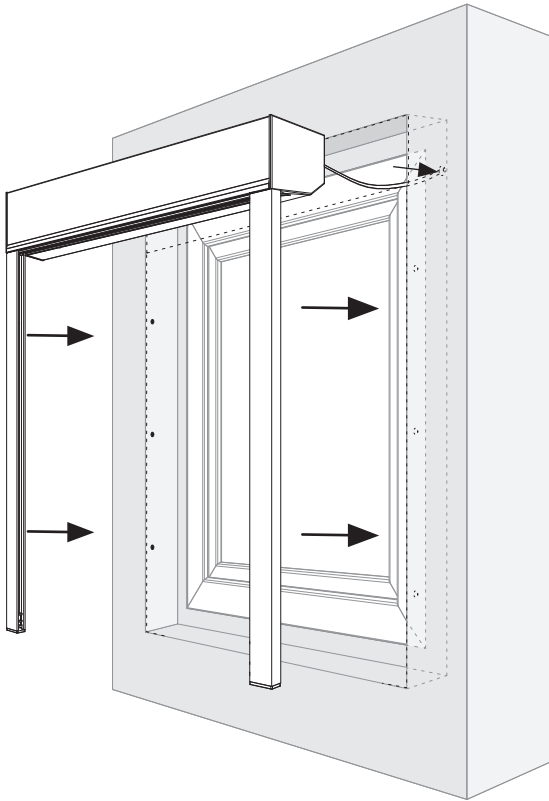
4 ^{V3}

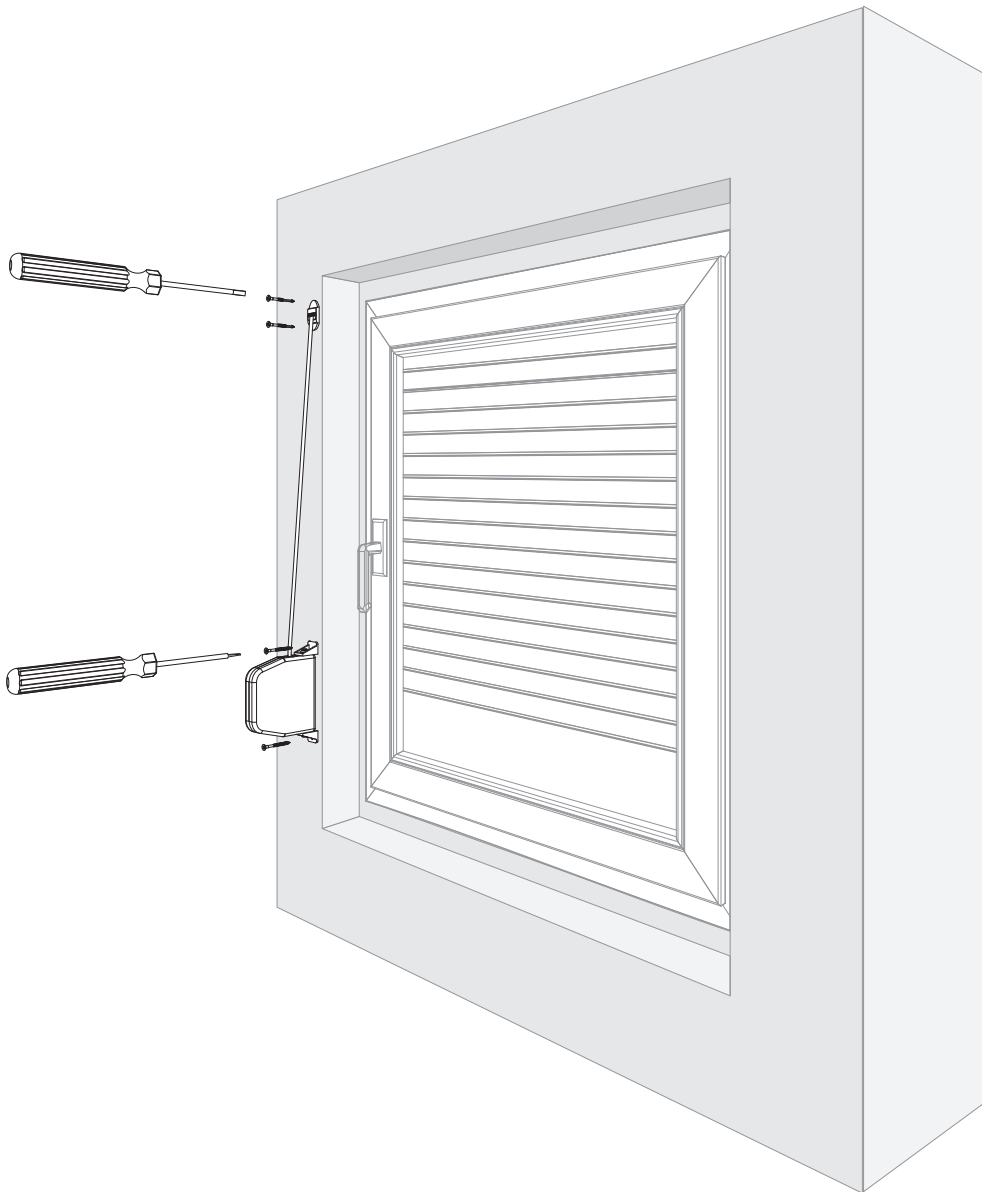
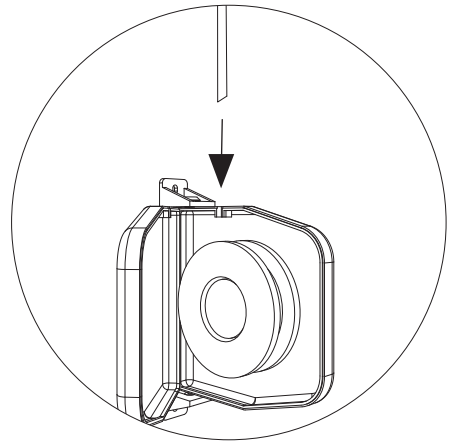
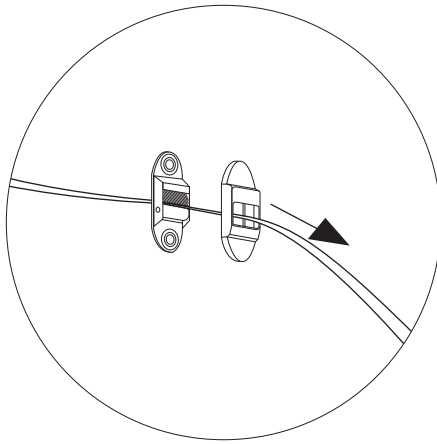
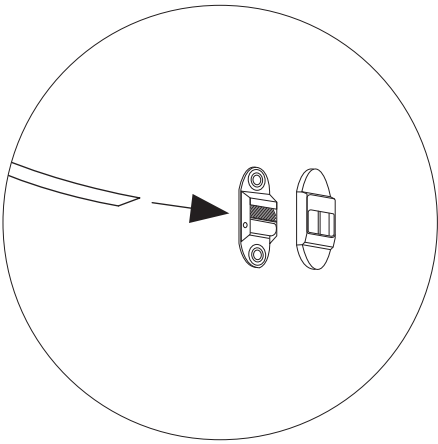
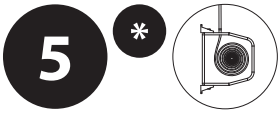

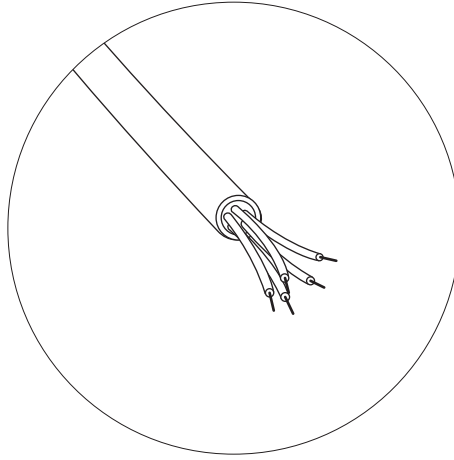

DEUTSCH

Schalten Sie die Versorgung ab, bevor Sie den Installationsvorgang beginnen. In manchen Ländern dürfen Elektroinstallation nur von qualifizierten Spezialisten bzw. Elektrofachkräften vorgenommen werden. Für weitere Informationen nehmen Sie Kontakt mit einschlägigen Einrichtungen auf.

ENGLISH

Before starting the installation process, disconnect from power supply. In some countries, only qualified specialists or electricians are authorised to build electrical installations. To obtain more information, consult appropriate institutions.

FRANÇAIS

Couper l'alimentation avant de débiter le montage. Dans certains pays, le raccordement électrique doit être réalisé uniquement par un installateur ou un électricien qualifié. Pour plus d'informations, veuillez contacter les organismes compétents.

POLSKI

Odłącz zasilanie zanim rozpocznie proces instalacji. Poszczególne państwa zastrzegają wykonywanie instalacji elektrycznych tylko przez wykwalifikowanych specjalistów lub elektryków. Aby uzyskać więcej informacji skontaktuj się z odpowiednimi instytucjami.

ITALIANO

Scollegare l'alimentazione prima di iniziare l'installazione. Alcuni Paesi consentono la realizzazione degli impianti elettrici esclusivamente ad esperti o elettricisti qualificati. Per ulteriori informazioni, contattare le istituzioni competenti.

SPAGNOLO

Desconecte la alimentación antes de comenzar la instalación. Algunos países restringen la realización de la instalación eléctrica únicamente por parte de especialistas cualificados o electricistas. Para obtener más información, póngase en contacto con los organismos correspondientes.

NEDERLANDS

Trek de stekker uit het stopcontact voordat u met de installatie begint. In bepaalde landen mag de montage van elektrische installaties alleen door een elektromonteur of elektricien worden uitgevoerd. Neem voor meer informatie contact op met de toepasselijke instituten.

TÜRK

Montaj işlemine başlamadan önce elektrik bağlantısını kesiniz. Bazı ülkelerde elektrik tesisatlarının montajı yalnızca kalifiye uzman veya elektrikçiler tarafından yapılabilir. Daha fazla bilgi almak için ilgili kurumlara başvurunuz.